



Designation: D5716/D5716M – 20

Standard Test Method for Measuring the Rate of Well Discharge by Circular Orifice Weir¹

This standard is issued under the fixed designation D5716/D5716M; the number immediately following the designation indicates the year of original adoption or, in the case of revision, the year of last revision. A number in parentheses indicates the year of last reappraisal. A superscript epsilon (ϵ) indicates an editorial change since the last revision or reappraisal.

1. Scope*

1.1 This test method covers construction and operation of a circular orifice weir for measuring the discharge from a well. This test method is a part of a series of standards prepared on the in situ determination of hydraulic properties of aquifer systems by single- or multiple-well tests. Selection of a well discharge measurement test method is described in Guide [D5737M](#).

1.2 The discharge rate determined by this test method is commonly used for a number of aquifer test methods and to provide information for the evaluation of well and pump performance.

1.3 *Limitations*—This test method is limited to the description of a method common to hydraulic engineering for the purpose of groundwater discharge measurement in temporary or test conditions.

1.4 Much of the information presented in this test method is based on work performed by the Civil Engineering Department of Purdue University during the late 1940s. The essentials of that work have been presented in a pamphlet prepared by Layne-Bowler, Inc.² and updated by Layne Western Company, Inc.³

1.5 All observed and calculated values shall conform to the guidelines for significant digits and rounding established in Practice [D6026](#).

1.5.1 The procedures used to specify how data are collected/recorded and calculated in this standard are regarded as the industry standard. In addition they are representative of the significant digits that should generally be retained. The procedures used do not consider material variation, purpose for obtaining the data, special purpose studies, or any consider-

¹ This test method is under the jurisdiction of ASTM Committee [D18](#) on Soil and Rock and is the direct responsibility of Subcommittee [D18.21](#) on Groundwater and Vadose Zone Investigations.

Current edition approved June 1, 2020. Published June 2020. Originally approved in 1995. Last previous edition approved in 2015 as D5716–15. DOI: 10.1520/D5716_D5716M-20.

² *Measurement of Water Flow Through Pipe Orifice With Free Discharge*, Bulletin 501, Layne-Bowler, Inc., Mission, KS, 1958.

³ *Measurement of Water Flow Through Pipe Orifice With Free Discharge*, Layne-Western Company, Inc., Mission, KS, 1988.

ations for the user's objectives; and it is common practice to increase or reduce significant digits of reported data to be commensurate with these considerations. It is beyond the scope of this document to consider significant digits used analysis methods for engineering design.

1.6 *Units*—The values stated in either SI units or inch-pound units are to be regarded separately as standard. The values stated in each system may not be exact equivalents; therefore, each system shall be used independently of the other. Combining values from the two systems may result in nonconformance with the standard. Reporting of test results in units other than SI shall not be regarded as nonconformance with this standard.

1.7 *This standard does not purport to address all of the safety concerns, if any, associated with its use. It is the responsibility of the user of this standard to establish appropriate safety, health, and environmental practices and determine the applicability of regulatory limitations prior to use.*

1.8 *This international standard was developed in accordance with internationally recognized principles on standardization established in the Decision on Principles for the Development of International Standards, Guides and Recommendations issued by the World Trade Organization Technical Barriers to Trade (TBT) Committee.*

2. Referenced Documents

2.1 *ASTM Standards*:⁴

[D653 Terminology Relating to Soil, Rock, and Contained Fluids](#)

[D3740 Practice for Minimum Requirements for Agencies Engaged in Testing and/or Inspection of Soil and Rock as Used in Engineering Design and Construction](#)

[D5737M Guide for Methods for Measuring Well Discharge](#)

[D6026 Practice for Using Significant Digits in Geotechnical Data](#)

2.2 *Other Documents*:

[GWPD 10 Estimating discharge from a pumping well by use of a circular orifice weir, United States Geological Survey](#)

⁴ For referenced ASTM standards, visit the ASTM website, www.astm.org, or contact ASTM Customer Service at service@astm.org. For *Annual Book of ASTM Standards* volume information, refer to the standard's Document Summary page on the ASTM website.

*A Summary of Changes section appears at the end of this standard

3. Terminology

3.1 *Definitions:*

3.1.1 For definitions of common technical terms used in this standard, refer to Terminology D653.

3.2 *Definitions of Terms Specific to This Standard:*

3.2.1 *circular orifice weir*—a circular restriction in a pipe that causes back pressure that can be measured in a piezometer tube.

3.2.1.1 *Discussion*—Also called *orifice tube* and *orifice meter*.

3.3 *Symbols and Dimensions Used in this Standard:*

3.3.1 *A*—orifice plate open area [L^2].

3.3.2 *C*—coefficient of discharge for the orifice [*nd*].

3.3.3 *g*—acceleration due to gravity [LT^{-2}].

3.3.4 *h*—head in manometer [L].

3.3.5 *Q*—control well discharge [L^3T^{-1}].

3.3.6 *o*—orifice diameter [L].

3.3.7 *d*—pipe inside diameter [L].

4. Summary of Test Method

4.1 This test method involves pumping a control well at a constant or variable rate through a circular orifice weir for a given period of time. Discharge is through an orifice weir that allows determination of the discharge rate.

5. Significance and Use

5.1 This test method provides design information for construction of an orifice weir. It also describes setup, operation, inspection, calculation of discharge, and reporting. The accu-

racy of a circular weir decreases at low flows. The use of a circular orifice weir requires a constant flow velocity over the period of measurement. The results may be affected by the piezometers distance from the orifice plate. This equipment may not be appropriate for measuring flows on small wells, or wells with limited recharge.

5.2 Aquifer testing has been conducted for the purposes of production and pressure relief well design and water resource assessment. Production wells are used for public and industrial water supplies, hydraulic controls, and groundwater capture. Pressure relief wells are for hydraulic controls. Test wells are for the purpose of water resource assessment.

5.3 Discharge must also be known for certain methods to evaluate well and pump performance.

NOTE 1—Practice D3740 provides evaluation factors for the activities in this standard. The quality of the result produced by this standard is dependent on the competence of the personnel performing it and the suitability of the equipment and facilities used. Agencies that meet the criteria of Practice D3740 are generally considered capable of competent and objective testing/sampling/inspection/etc. Users of this standard are cautioned that compliance with Practice D3740 does not in itself assure reliable results. Reliable results depend on many factors; Practice D3740 provides a means of evaluating some of those factors.

6. Apparatus

6.1 *Construction of a Circular Orifice Weir*—A construction diagram of a circular orifice weir is presented in Fig. 1.⁵ The circular orifice is a hole located in the center of a plate attached to a straight horizontal length of discharge pipe. The pipe is at

⁵ Driscoll, F. G., *Ground Water and Wells*, Johnson Division, St. Paul, MN, 1986, pp. 537–541.

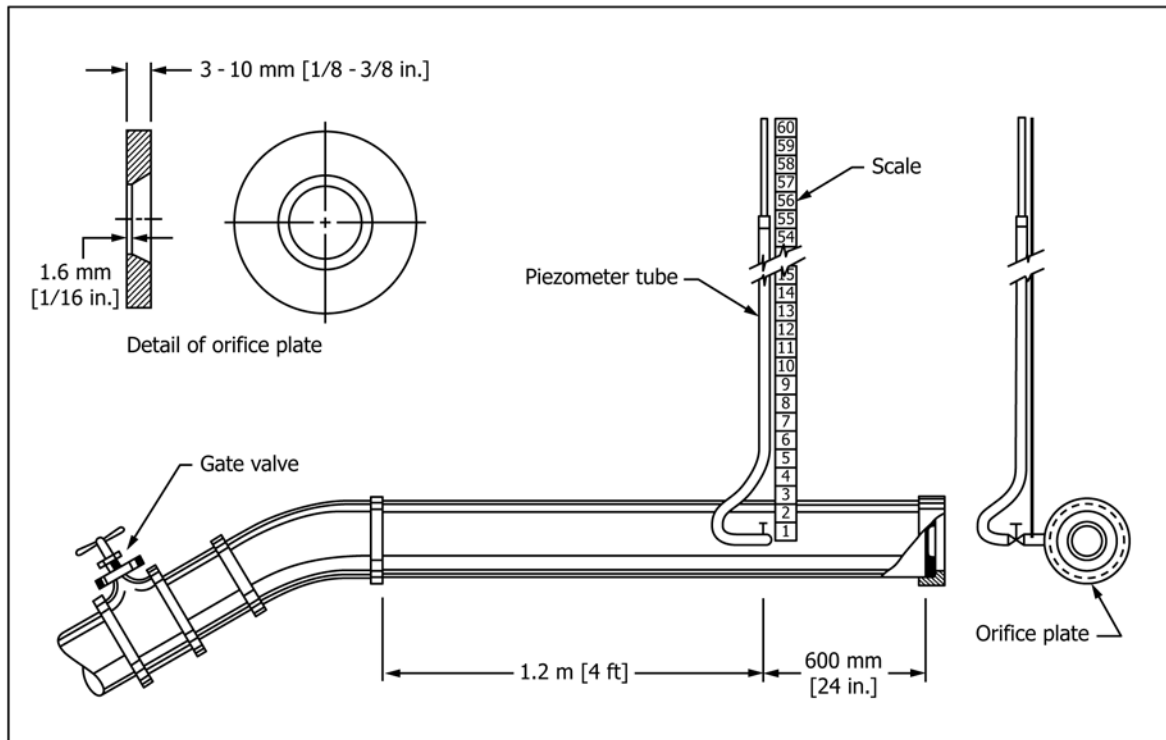

FIG. 1 Construction of a Circular Orifice Weir⁵